

REPAIR LIST FOR  
RING OILING, SELF OILING  
STANDARD MILL

9 to 14 FOOT  
Windmill-Parts.com

ADOPTED JANUARY 1st, 1923

Name of Repair	Repair Number	9' AA	10' A	12' B	14' C
Main Casting	1 RO	\$ 7.00	\$ 9.50	\$12.50	\$19.00
Bearing Cap for No. 1	2 RO	1.50	2.00	2.50	3.25
Oiling Rings (set 2)	160 RO	.50	.60	.80	1.00
Felt Washers (set 2)	161 RO	.30	.40	.50	.60
End Thrust Washers (set 2)	162 RO	.30	.40	.50	.60
Pitman, Wood Part Only	163 RO	.55	.70	.90	1.20
Pitman, Lower Casting	164 RO	.50	.75	.75	1.00
Oiling Ring	165 RO	.40	.50	.50	.60
Pitman Upper Casting	166 RO	.25	.30	.40	.50
Lid for Upper Casting	167 RO	.30	.30	.30	.30
Oil Cup for Upper Casting, Lower End	168 RO	.15	.15	.15	.15
Pitman Complete as Assembled	170 RO	2.15	2.70	3.00	3.75
Stud Pin	30 RO	.60	.80	1.00	1.25
Wrist Pin	31 RO	.75	1.00	1.25	1.50
Complete Spider, Shaft and Face Plate with Rings as Packed		8.30	10.70	13.70	19.00
Complete Box of Parts as Packed	57 RO	19.90	25.20	30.95	43.75
Complete Main Casting as Packed	58 RO	14.50	19.65	25.50	39.65

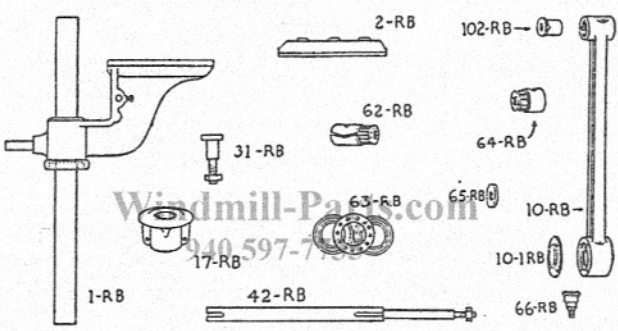

REPAIR LIST OF  
STANDARD ROLLER BEARING MILLS  
9 TO 14 FOOT

ADOPTED JANUARY 1st, 1923

Name of Parts	Repair Number	9' AA	10' A	12' B	14' C
Main Casting	1 RB	\$7.50	\$10.00	\$13.00	\$20.00
Bearing Cap for No. 1	2 RB	1.75	2.25	3.00	4.00
Tower Cap	17 RB	1.50	1.50	2.00	3.00
Stud Pin	30 RB	.75	.85	.90	1.00
Wrist Pin (Hardened)	31 RB	1.00	1.25	1.50	2.00
Pitman Casting	10 RB	2.00	2.50	2.75	3.50
Pitman Cap	10-1 RB	4.00	.50	.50	.60
Pitman Bronze Bushing	10-2 RB	.50	.60	.65	.75
Pitman Roller Bearing	64 RB	2.50	3.00	3.50	4.00
Pitman Felt Washer	65 RB	.25	.30	.35	.40
Steel Grease Cup for No. 10	66 RB	.25	.25	.30	.30
Pitman Complete		5.00	6.00	7.00	8.50
Main Shaft (Hardened)	4-2 RB	4.00	5.00	6.00	7.50
Roller Bearing for No. 4-2 (set)	62 RB	4.50	5.00	6.00	8.00
Ball Bearings for Turntable	63 RB	4.50	4.50	6.50	10.00
Spider, Shaft and Face Plate complete with Roller Bearings		12.50	16.00	20.00	26.50
Complete Box of Parts as Packed	57 RB	27.00	31.50	40.00	57.00
Complete Main Castings as Packed	58 RB	14.50	19.50	26.00	39.00

No.	Description	9ft. AA	10ft. A	12ft. B	14ft. C
21	Pull Out Chain with No. 22	.75	.50	\$1.00	\$1.25
22	Link and Swivel for No. 21	.25	.25	.25	.40
23	Gear Cover	.40	.50	.65	1.00
24	Bolt for No. 23	.06	.08	.08	1.10
25	Piston Rod	1.80	2.00	2.60	4.50
26	Pull Out Rod	.40	.50	.60	.75
27	Weight Arm	1.25	1.40	1.85	2.35
28	Rudder Vane Bar	2.50	3.00	4.00	6.00
28-1	Rudder Vane Top Truss Rod (Large)	1.50	1.70	2.70	4.00
28-1	Rudder Vane Side Truss Rod (Small)	.60	.60	.60	1.80
29	Side Vane Bar	1.40	1.40	1.80	3.85
29-1	Side Vane Clip	.20	.20	.25	.30
30	Wood Screws for No. 29-1	.08	.08	.08	.85
31	Stud Pin	.60	.70	.75	.85
31	Wrist Pin	.65	.85	.85	1.25
32	Brass Washer for 14-ft. Wrist Pin	1.50	2.10	2.80	2.5
33	Counterpoise	.80	.80	1.15	1.15
33	Bolt for No. 33	.10	.15	.15	.20
34	Pump Pin	.20	.20	.20	.20
35	Pump Connection	.60	.60	.60	.60
36	Bolts for No. 34	.20	.20	.20	.20
36	Pump Poles (2 pcs.)	1.80	2.00	2.00	2.50
37	Pump Poles Splice Plates (Pair)	.30	.30	.30	.30
38	Bolts for No. 37	1.15	1.15	1.15	1.15
38	Pull Out Wire (32 ft.)	.50	.50	.50	.50
39	Full Out Lever	.85	.85	.85	.85
40	Lower Hooks (4)	.70	.70	.70	.70
41	Yard Hooks (4)	1.20	1.50	2.00	3.00
42	Wheel Sections (each)	2.50	2.50	2.50	4.25
43	Wheel Slat (each)	.20	.20	.20	.20
44	Short Rim	.45	.45	.45	.45
45	Long Rim	.45	.45	.45	.45
46	Wheel Bolts (set)	1.00	1.25	1.75	2.50
47	Wood Wheel Braces (each)	2.25	3.00	4.80	8.00
48	Wood Wheel Braces (set)	.45	.50	.50	1.00
49	Rudder Vane	5.50	6.00	7.80	10.50
50	Rudder Vane Stalks	.70	.75	1.00	1.20
51	Rudder Vane Ribs	1.25	1.40	1.60	2.50
52	Side Vane	.25	.25	.25	.25
53	Side Vane Stalks	.25	.25	.25	.25
54	Side Vane Ribs	.25	.25	.25	.25
55	Complete Mill Bolts (set)	1.50	2.00	2.50	3.00
56	Complete Mill Bolts (set)	1.50	2.00	2.50	3.00
57	Complete Box of Parts as Packed	13.15	17.40	22.30	36.10
58	Complete Main Casting as Packed	14.50	19.65	25.50	39.65
59	Complete Bundle of Irons as Packed	8.10	10.50	13.10	16.90
60	Complete Weight Arm as Packed	1.70	1.90	2.50	3.35

Axtell Co., Fort Worth

940 597-7735  
Windmill-Parts.com

Windmill  
940 59